The MP-Series of Hydraulic Pressure Intensifiers



Applications:

Hydraulic Workholding on Machine Tools

Static and Impulse Testing Equipment

Hydraulic Power Packs

Stone Chushing Machines

Subsea R.O.V.'s

Hydraulic Construction Tools

Press Applications

Demolition Tools

Pressure Die Casting Machines

Quick Die Changing Equipment

Scanwill

Fluid Power ApS

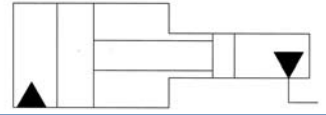

The MP-T Series



- In-Line Pressure Intensifier
- Rating to 800 Bar / 11,600 PSI
- Multiple Intensifications
- Reciprocating - Continuous Flow
- High Pressure Valves integrated

Page 4

The MP-C Series



- Cetop D03/NG6 Pressure Intensifier
- Rating to 500 Bar / 7,000 PSI
- Multiple Intensifications
- Reciprocating - Continuous Flow
- High Pressure Valves integrated

Page 5

The MP-F Series



- Flange-On Pressure Intensifier
- Rating to 700 Bar / 10,000 PSI
- Multiple Intensifications
- Reciprocating - Continuous Flow
- High Pressure Valves integrated

Page 6

The MP-2000 Series



- In-Line Pressure Intensifier
- Rating to 2,000 Bar / 29,000 PSI
- Multiple Intensifications
- Reciprocating - Continuous Flow
- High Pressure Valves integrated

Page 7

The MP-M Series



- In-Line Pressure Intensifier for flows up to 35 LPM
- Rating to 800 Bar / 11,600 PSI
- Multiple Intensifications
- Reciprocating - Continuous Flow
- High Pressure Valves integrated

Page 8

The MP-L Series



- In-Line Pressure Intensifier for flows up to 80 LPM
- Rating to 800 Bar / 11,600 PSI
- Multiple Intensifications
- Reciprocating - Continuous Flow
- High Pressure Valves integrated

Page 9

Specials & Accessories

Page 10

Application Examples

Page 11

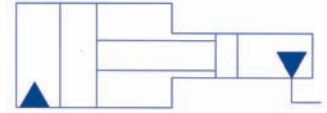

Function:

The MP-Series of hydraulic pressure intensifiers are reciprocating, and will automatically increase a supplied pressure to a higher end pressure. Fig. 1 shows the basic principle of the intensifiers, consisting of a piston arrangement and a Piston Control Valve, PCV. The position of the pistons will at the end of every stroke prompt a signal S to the PCV, which makes this change position, ensuring the pistons are moving in the opposite direction. This cycle will continue until the end pressure has been reached. At this point the system stop, and will now only move to maintain the end pressure.

Fig. 1:

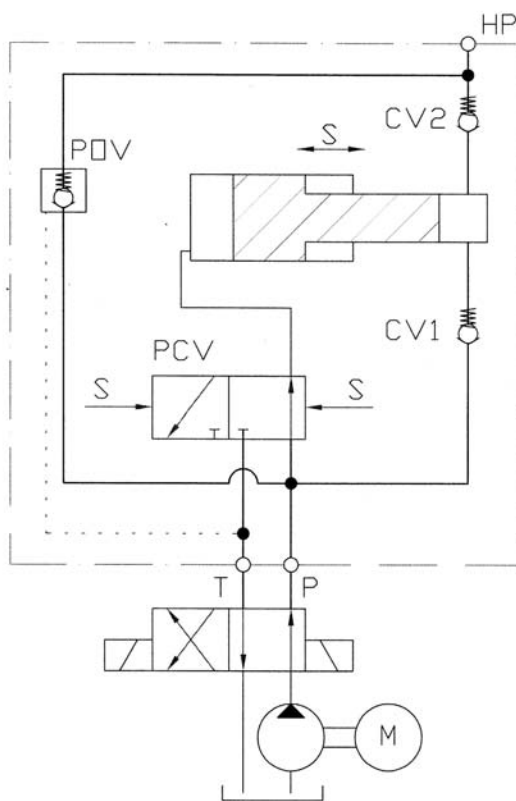

The Cycle:

When a hydraulic fluid is supplied to the P-connection of the intensifier and the T-connection is connected to tank, the oil will be directed through the check valves CV1 and CV2 to the high pressure connection HP. If the internal pilot operated check valve POV is incorporated the oil will go straight to the HP connection. In this situation all the flow supplied goes to the high pressure side ensuring a fast filling of the system. When pump pressure has been reached, the intensifier pistons will deliver the flow to the high pressure side, and continue to do so until the required end pressure has been reached. The pistons then stop, and will only move to make up for a pressure loss due to leakage or consumption. A general flow curve showing how the intensifier works is shown in Fig.2. For evacuating the high pressure side the internal POV is used. This valve is opened by directing the supplied pressure to the T-port and connecting the P-port to tank. This allows the oil from the high pressure side to flow directly back to tank.

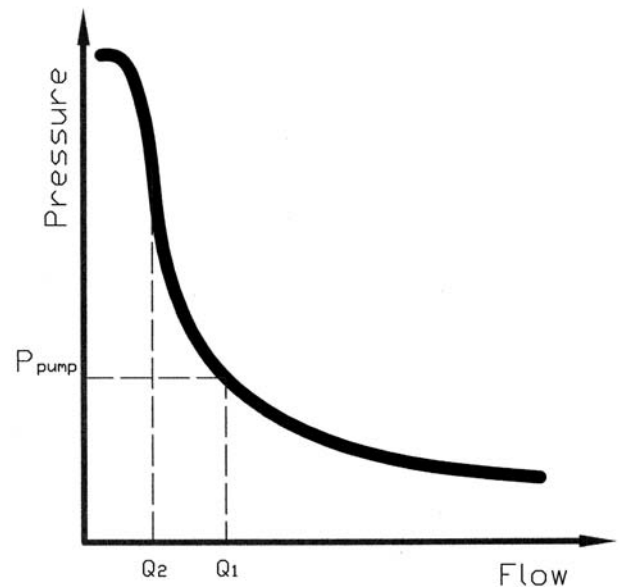

General Data:

Material:	Body parts of cast iron, pistons and valves of steel, O-rings of NBR
Surface coating:	Zinc-Chrome silver blue finish
Temperature range:	-40° C to +120° C
Fluids:	Recognised hydraulic fluids and water glycol only. For other fluids contact factory or distributor.
Filtration:	10 micron nominal, maximum 19/16 according to ISO 4406

The MP-T

Pressure Intensifier

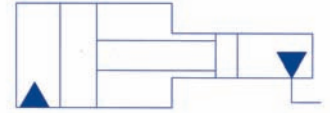

The MP-T is an in-line pressure intensifier designed to be positioned in a low pressure hydraulic system, and will provide higher pressure exactly where needed (max. 800 bar). Having all the required high pressure valves incorporated, the need for additional high pressure components is minimized ensuring a cost effective system. Control of the high pressure side is achieved by valves on the low pressure side through the intensifier which adds to safety. The intensifiers are offered with 7 different intensification ratios as standard with additional ratios on request to meet most intensification requirements. The compact design ensures easy installation in new as well as existing hydraulic circuits.



The standard MP-T will provide pressure intensification as required. As an option a built in pilot operated check valve, POV, allows the high pressure side to be relieved through the intensifier (see page 3).

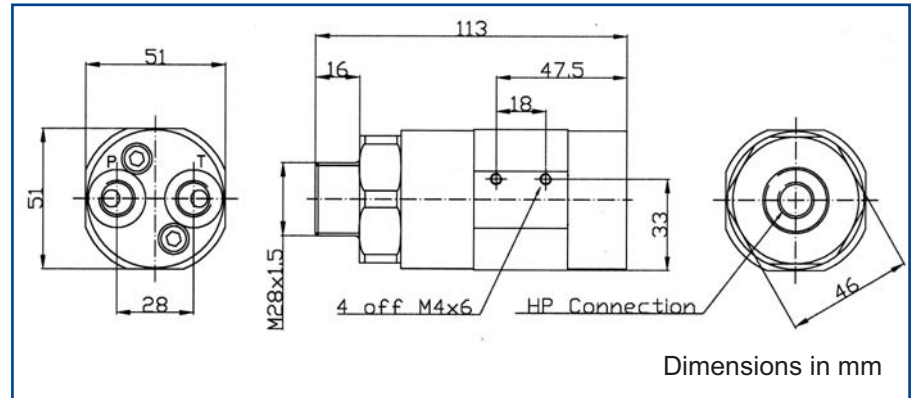

Flow & Pressure:

The supplied flow and pressure to the MP-T are dependant on the intensification ratio chosen. The table shows the flow and pressure for each model. Flow Q1 is when the pump pressure has been reached, and flow Q2 is moving up the vertical part of the curve (see graph on page 2). Please note flow values will vary with the viscosity of the fluid. Inlet values must not be exceeded.

Ratio (i)	Inlet Flow (LPM / GPM)	Outlet Flow Q1 (LPM / GPM)	Outlet Flow Q2 (LPM / GPM)	Inlet Pressure (Bar / Psi)	Outlet Pressure (Bar / Psi)
1.5	8.0 / 2.1	0.8 / 0.21	0.3 / 0.08	200 / 2,900	300 / 4,350
2.0	8.0 / 2.1	0.8 / 0.21	0.2 / 0.08	200 / 2,900	400 / 5,800
3.4	15.0 / 4.0	2.2 / 0.58	0.5 / 0.13	200 / 2,900	680 / 9,860
4.0	14.0 / 3.7	1.8 / 0.47	0.4 / 0.10	200 / 2,900	800 / 11,600
5.0	14.0 / 3.7	1.4 / 0.37	0.3 / 0.08	160 / 2,320	800 / 11,600
7.0	13.0 / 3.4	1.1 / 0.29	0.2 / 0.05	114 / 1,653	800 / 11,600
9.0	13.0 / 3.4	0.7 / 0.19	0.1 / 0.03	89 / 1,290	800 / 11,600

Ordering Code:

First decide whether the pilot operated check valve, POV, is required, then decide the intensification ratio (i), and finally decide the connections (BSP or UNF).

Example:

MP-T with POV, intensification 5.0 and BSP connections: **MP-T-P-5.0-G**

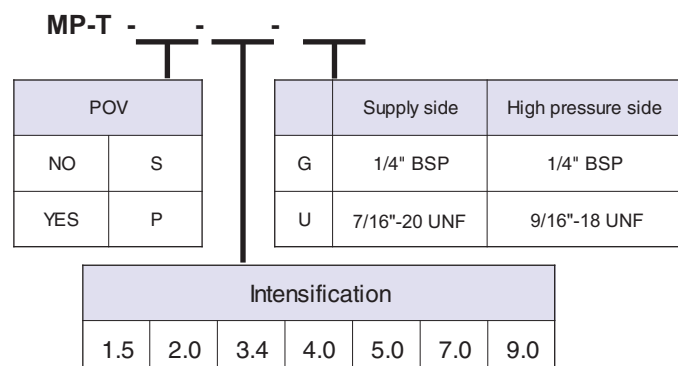

The MP-C

Pressure Intensifier

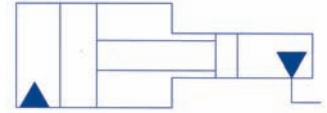

The MP-C pressure intensifier is designed for the cetop-system (D03/NG6) and will increase a supplied pressure to the higher end pressure required (max. 500 bar). Having high pressure valves incorporated, including the POV (see page 3), a pilot operated check valve, for relieving the high pressure side, the MP-C offers a cost effective solution for intensification needs. Controlling the high pressure side is achieved by valves on the low pressure side through the MP-C, allowing the intensifier to be installed in most existing as well as new hydraulic circuits. The MP-C intensifier is offered with 7 different intensification ratios as standard with additional ratios on request to meet most intensification requirements.



The MP-C in a system:

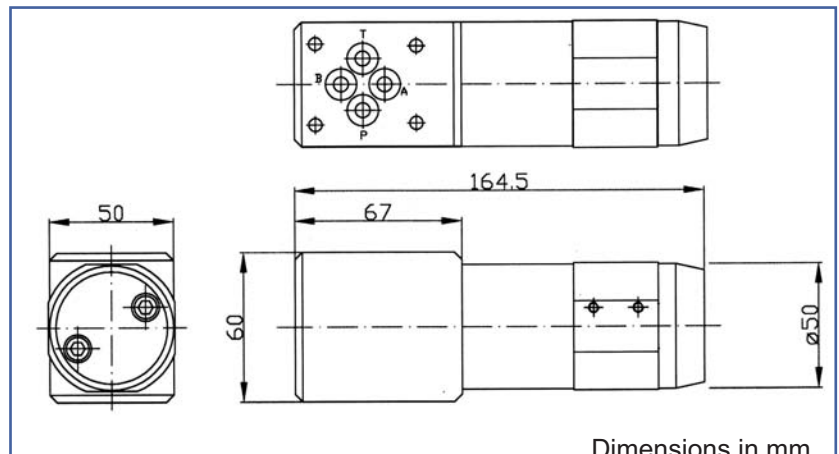
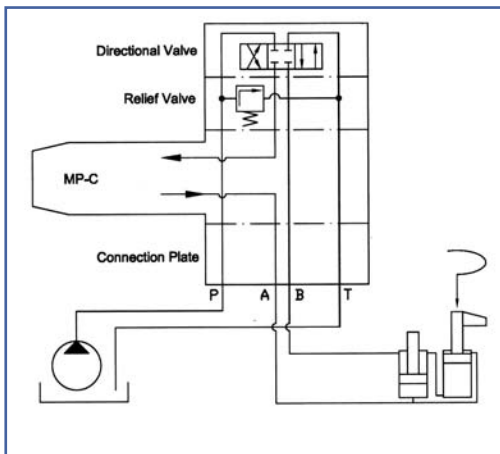

Flow & Pressure:

The supplied flow and pressure to the MP-C are dependant on the intensification ratio chosen. The table shows the flow and pressure for each model. Flow Q1 is when the pump pressure has been reached, and flow Q2 is moving up the vertical part of the curve (see graph on page 2). Please note flow values will vary with the viscosity of the fluid. Inlet values must not be exceeded.

Ratio (i)	Inlet Flow (LPM / GPM)	Outlet Flow Q1 (LPM / GPM)	Outlet Flow Q2 (LPM / GPM)	Inlet Pressure (Bar / Psi)	Outlet Pressure (Bar / Psi)
1.5	8.0 / 2.1	0.8 / 0.21	0.3 / 0.08	200 / 2,900	300 / 4,350
2.0	8.0 / 2.1	0.8 / 0.21	0.2 / 0.08	200 / 2,900	400 / 5,800
3.4	15.0 / 4.0	2.2 / 0.58	0.5 / 0.13	147 / 2,132	500 / 7,250
4.0	14.0 / 3.7	1.8 / 0.47	0.4 / 0.10	125 / 1,812	500 / 7,250
5.0	14.0 / 3.7	1.4 / 0.37	0.3 / 0.08	100 / 1,450	500 / 7,250
7.0	13.0 / 3.4	1.1 / 0.29	0.2 / 0.05	71 / 1,036	500 / 7,250
9.0	13.0 / 3.4	0.7 / 0.19	0.1 / 0.03	56 / 806	500 / 7,250

Ordering Code:

MP-C - T

Intensification						
1.5	2.0	3.4	4.0	5.0	7.0	9.0

Example:

MP-C with intensification 4.0: **MP-C-4.0**

The MP-F

Pressure Intensifier

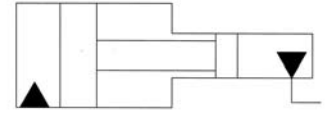

The MP-F pressure intensifier is a flange-on model, designed to be mounted to a hydraulic block. The MP-F will increase a supplied pressure to the higher end pressure required (max. 700 bar). Having high pressure valves incorporated, including the POV (see page 3), a pilot operated check valve, for relieving the high pressure side, the MP-F offers a cost effective solution for intensification needs. Controlling the high pressure side is achieved by valves on the low pressure side through the MP-F, allowing the intensifier to be installed in most existing as well as new hydraulic circuits. The MP-F intensifier is offered with 5 different intensification ratios as standard with additional ratios on request to meet most intensification requirements.

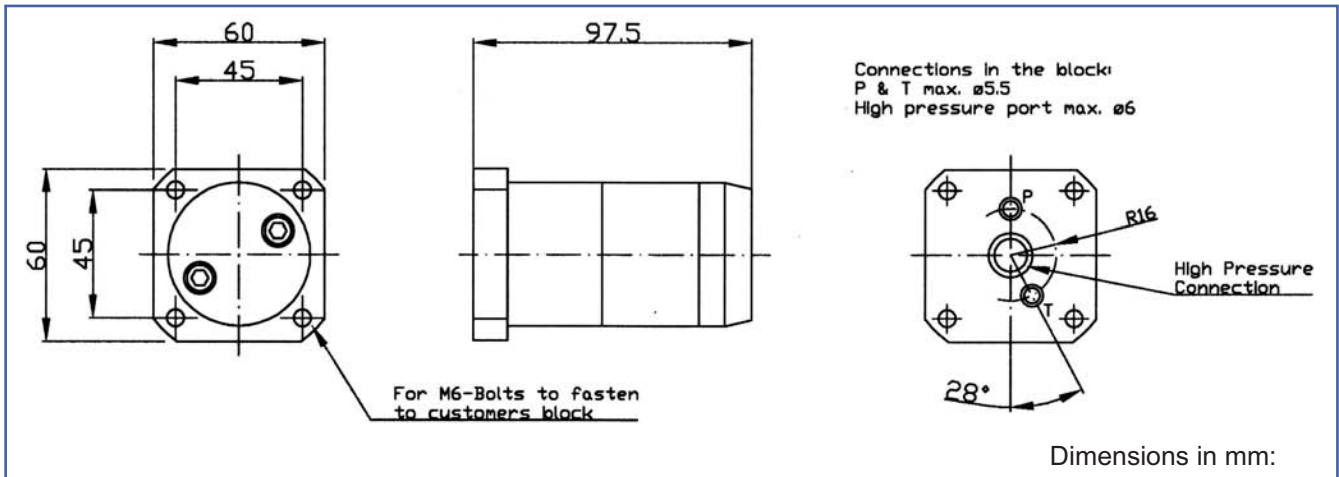

Flow & Pressure:

The supplied flow and pressure to the MP-F are dependant on the intensification ratio chosen. The table shows the flow and pressure for each model. Flow Q1 is when the pump pressure has been reached, and flow Q2 is moving up the vertical part of the curve (see graph on page 2). Please note flow values will vary with the viscosity of the fluid. Inlet values must not be exceeded.

Ratio (i)	Inlet Flow (LPM / GPM)	Outlet Flow Q1 (LPM / GPM)	Outlet Flow Q2 (LPM / GPM)	Inlet Pressure (Bar / Psi)	Outlet Pressure (Bar / Psi)
2.0	8.0 / 2.1	0.8 / 0.21	0.2 / 0.08	200 / 2,900	400 / 5,800
3.4	15.0 / 4.0	2.2 / 0.58	0.5 / 0.13	200 / 2,900	680 / 9,860
4.0	14.0 / 3.7	1.8 / 0.47	0.4 / 0.10	175 / 2,538	700 / 10,150
5.0	14.0 / 3.7	1.4 / 0.37	0.3 / 0.08	140 / 2,030	700 / 10,150
7.0	13.0 / 3.4	1.1 / 0.29	0.2 / 0.05	100 / 1,450	700 / 10,150

Ordering Code:

MP-F - T

Intensification				
2.0	3.4	4.0	5.0	7.0

Example:

MP-F with intensification 4.0: **MP-F-4.0**

The MP-2000

Pressure Intensifier

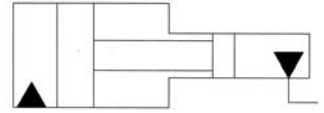

The MP-2000 is an in-line pressure intensifier designed to be positioned in a low pressure hydraulic system, and will provide higher pressure exactly where needed (max. 2.000 bar). Having all the required high pressure valves incorporated, the need for additional high pressure components is minimized ensuring a cost effective system. Controlling the high pressure side is achieved by valves on the low pressure side through the intensifier adding to safety. The intensifiers are offered with 4 different intensification ratios to meet most intensification requirements. The compact design ensures easy installation in new as well as existing hydraulic circuits.



The MP-2000 is offered with a pilot operated check valve (POV) integrated, which allows the high pressure side to be relieved through the intensifier (see page 3).

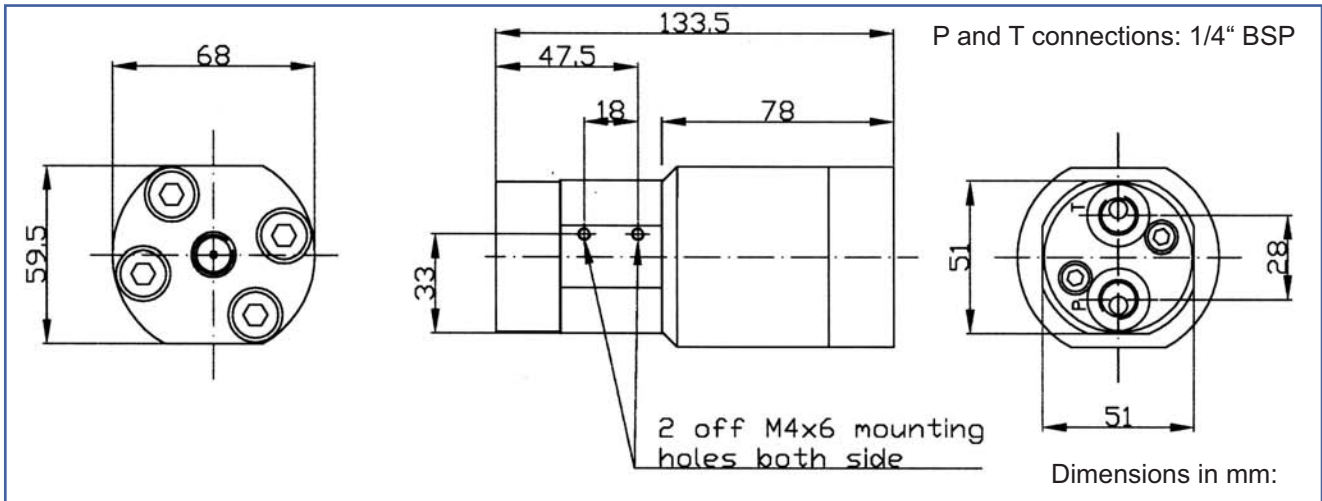

Flow & Pressure:

The supplied flow and pressure to the MP-2000 are dependant on the intensification ratio chosen. The table shows the flow and pressure for each intensification ratio. Flow Q1 is when the pump pressure has been reached, and flow Q2 is moving up the vertical part of the curve (see graph on page 2). Please note flow values will vary with the viscosity of the fluid. Inlet values must not be exceeded.

Ratio (i)	Inlet Flow (LPM / GPM)	Outlet Flow Q1 (LPM / GPM)	Outlet Flow Q2 (LPM / GPM)	Inlet Pressure (Bar / Psi)	Outlet Pressure (Bar / Psi)
7.0	12.0 / 3.17	1.1 / 0.29	0.2 / 0.05	200 / 2,900	1.400 / 20,300
10.0	12.0 / 3.17	0.7 / 0.18	0.2 / 0.05	200 / 2,900	2.000 / 29,000
13.0	10.0 / 2.64	0.5 / 0.13	0.1 / 0.02	154 / 2,233	2.000 / 29,000
16.0	10.0 / 2.64	0.4 / 0.10	0.1 / 0.02	125 / 1,812	2.000 / 29,000

Ordering Code:

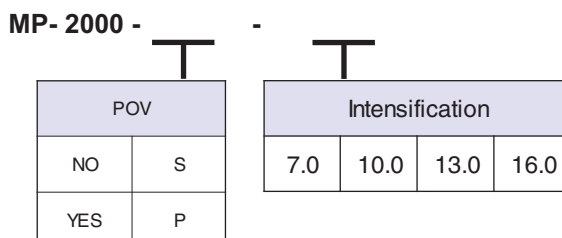

Example:

MP-2000 with the POV integrated and intensification 7.0: **MP-2000-P-7.0**

The MP-M

Pressure Intensifier

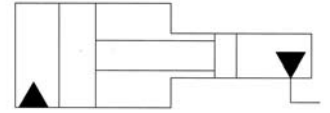

The MP-M pressure intensifier is an in-line model, designed to be positioned in a low pressure hydraulic system, and will provide high pressure exactly where needed. The MP-M will automatically increase a supplied pressure to the higher end pressure required (max. 800 bar). Having high pressure valves incorporated, including the POV (see page 3), a pilot operated check valve for relieving the high pressure side, the MP-M offers a cost effective solution for intensification needs. Controlling the high pressure side is done by valves on the low pressure side through the MP-M, allowing the intensifier to be installed in most existing as well as new hydraulic circuits. The MP-M intensifier is offered with 5 different intensification ratios as standard with additional ratios on request to meet most intensification requirements.

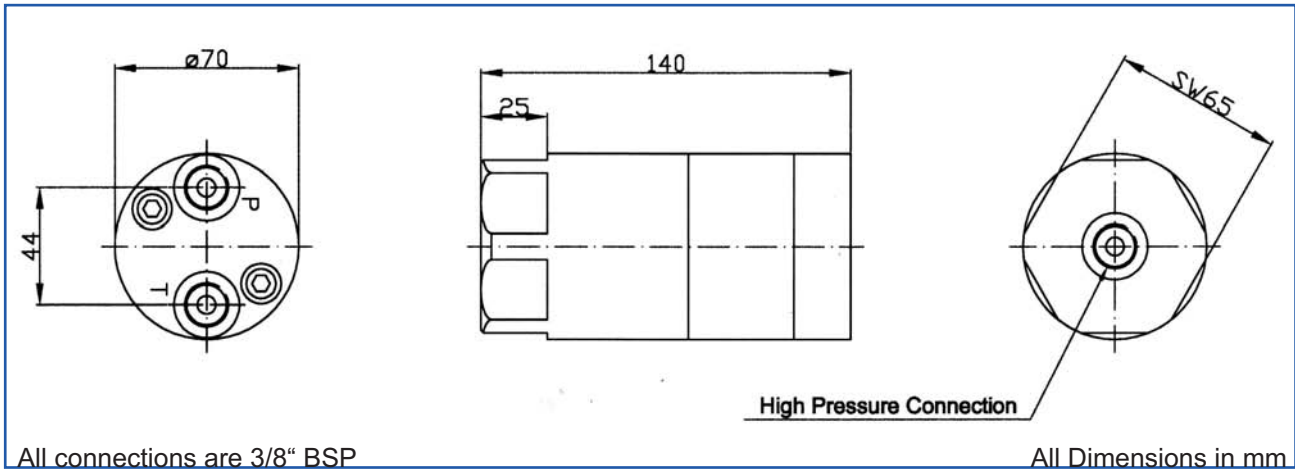

Flow & Pressure:

The supplied flow and pressure to the MP-M are dependant on the intensification ratio chosen. The table shows the flow and pressure for each model. Flow Q1 is when the pump pressure has been reached, and flow Q2 is moving up the vertical part of the curve (see graph on page 2). Please note flow values will vary with the viscosity of the fluid. Inlet values must not be exceeded.

Ratio (i)	Inlet Flow (LPM / GPM)	Outlet Flow Q1 (LPM / GPM)	Outlet Flow Q2 (LPM / GPM)	Inlet Pressure (Bar / Psi)	Outlet Pressure (Bar / Psi)
1.8	25.0 / 6.6	5.0 / 1.32	1.5 / 0.39	200 / 2,900	360 / 5,220
3.4	35.0 / 9.3	5.0 / 1.32	2.8 / 0.74	200 / 2,900	680 / 9,860
4.0	35.0 / 9.3	4.0 / 1.06	2.4 / 0.63	200 / 2,900	800 / 11,600
5.0	35.0 / 9.3	3.5 / 0.93	1.9 / 0.50	160 / 2,320	800 / 11,600
7.0	35.0 / 9.3	3.0 / 0.80	1.3 / 0.34	114 / 1,653	800 / 11,600

Ordering Code:

Example:

MP-M with intensification 4.0: **MP-M-4.0**

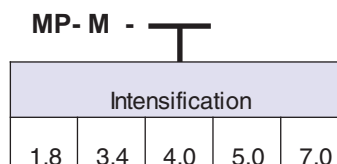

The MP-L

Pressure Intensifier

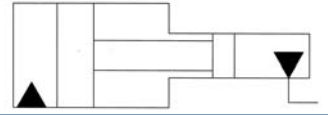

The MP-L pressure intensifier is an in-line model, designed for high flow applications, where it will provide high pressure exactly where needed. The MP-L will automatically increase a supplied pressure to the higher end pressure required (max. 800 bar). Having high pressure valves incorporated, including the POV (see page 3), a pilot operated check valve for relieving the high pressure side, the MP-L offers a cost effective solution for intensification needs. Controlling the high pressure side is done by valves on the low pressure side through the MP-L, allowing the intensifier to be installed in most existing as well as new hydraulic circuits. The MP-L intensifier is offered with 5 different intensification ratios as standard with additional ratios on request to meet most intensification requirements.

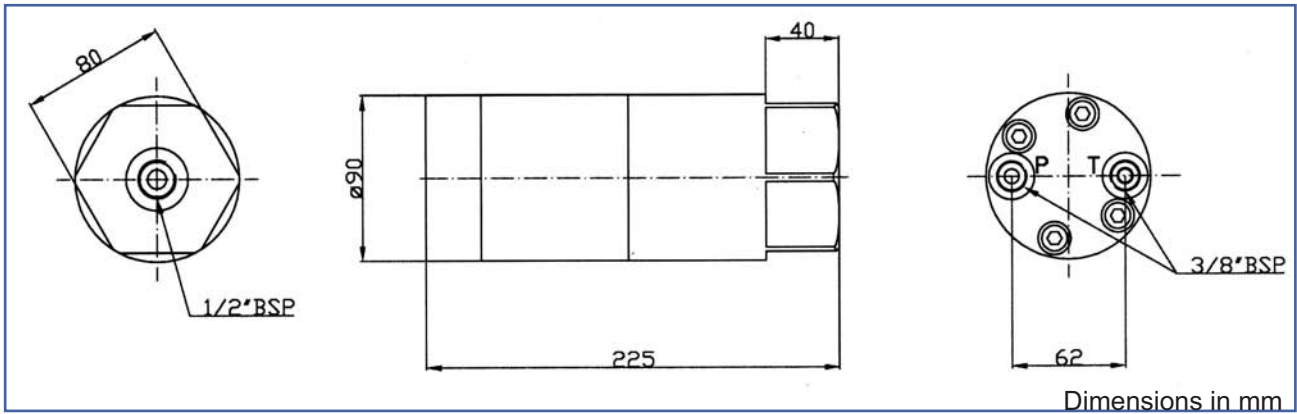

Flow & Pressure:

The supplied flow and pressure to the MP-L are dependant on the intensification ratio chosen. The table shows the flow and pressure for each model. Flow Q1 is when the pump pressure has been reached, and flow Q2 is moving up the vertical part of the curve (see graph on page 2). Please note flow values will vary with the viscosity of the fluid. Inlet values must not be exceeded.

Ratio (i)	Inlet Flow (LPM / GPM)	Outlet Flow Q1 (LPM / GPM)	Outlet Flow Q2 (LPM / GPM)	Inlet Pressure (Bar / Psi)	Outlet Pressure (Bar / Psi)
2.0	50.0 / 13.22	5.0 / 1.32	2.0 / 0.52	200 / 2,900	400 / 5,800
3.4	80.0 / 21.16	17.8 / 4.71	13.0 / 3.44	200 / 2,900	680 / 9,860
4.0	80.0 / 21.16	14.7 / 3.89	11.0 / 2.91	200 / 2,900	800 / 11,600
5.0	80.0 / 21.16	11.6 / 3.06	8.8 / 2.33	160 / 2,320	800 / 11,600
7.0	80.0 / 21.16	8.4 / 2.22	6.3 / 1.67	114 / 1,653	800 / 11,600

Ordering Code:

Example:

MP-L with intensification 4.0: **MP-L-P-4.0**

MP-L-P-

Intensification				
2.0	3.3	4.0	5.0	7.0

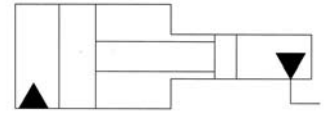

Specials:

The MP-T series of hydraulic pressure intensifiers is ideal for making specials, to meet the market demands. Below are two examples on specials made for customers.



The MP-L-2000 is based on the MP-L series, and is made for a concrete bursting application (demolition), where a combination of high flow and high pressure is needed. The MP-L-2000 is modified to deliver pressures up 2,500 Bar.



The MP-T-R pressure intensifier is based on the MP-T series, but modified to be inserted in a rotating application, where it rotates at 1,500 rpm, while intensifying a supplied pressure of 30 Bar to 210 Bar.

Accessories:



The M-Kit consists of two brackets which can be used to fasten the MP-Intensifiers to a base plate.

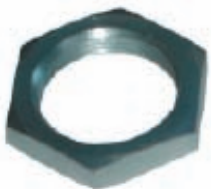

The M-Nut is a nut M28 x 1.5 to be used for mounting the MP-T pressure intensifier.

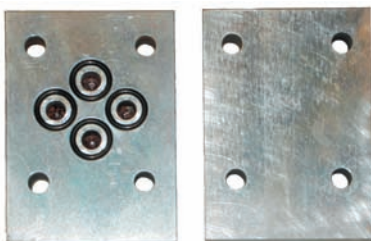

The NG-6 Top plate is offered to be used with the MP-C pressure intensifier, in situations where a closed top for the Cetop / NG6 block is required.

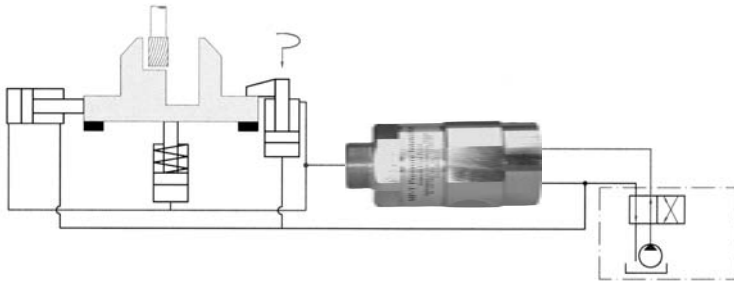
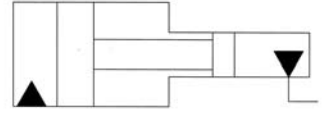

Hydraulic Workholding Circuits on machine tools is a major application area for the MP-series of hydraulic pressure intensifiers. Inserting the intensifier between the hydraulic system already on the machine tool and the hydraulic clamping components allows the higher pressure to be obtained and controlled from the supply side.

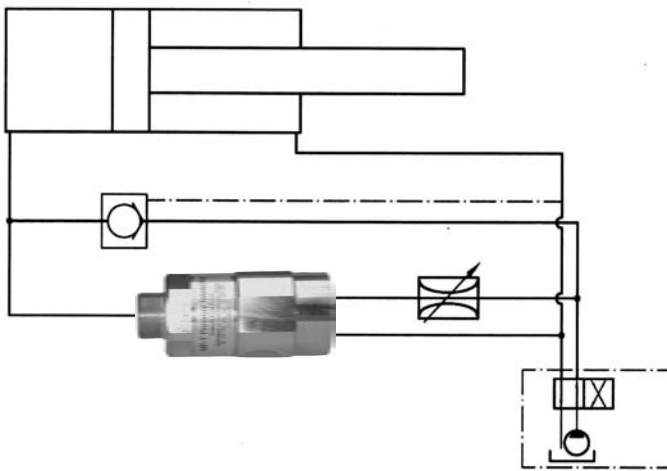

In **High Flow Applications** (plastic injection moulding machines, pressure die casting machines, demolition tools etc.) the MP-intensifiers are inserted parallel with a p.o. check valve, which is designed to take the full flow and pressure. This allows the full pump flow to be used to fill the cylinder, and subsequently the end pressure is delivered by the intensifier. During retract mode the external p.o. check valve allows the full flow to go back to tank. This setup allows you to get high pressure with a minimum of loss in cycle time.

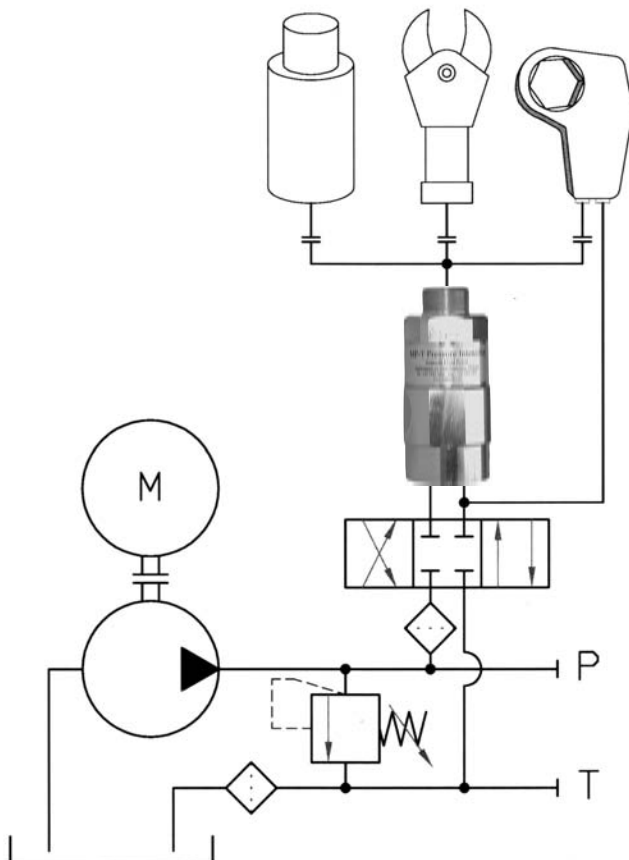

In **Hydraulic Power Packs**, the MP-intensifiers are used to give a high pressure output. This is achieved without changing the standard setup of the standard power pack, and presents a flexible and economical way of obtaining high pressure. Using the MP-Intensifiers enables the operation of high pressure tools directly from a low pressure power pack.

Scanwill

Fluid Power ApS



Scanwill

Fluid Power ApS

Sjællandsgade 24 Phone: +45 7442 3450
DK-6400 Sonderborg Fax: +45 7442 3430
Denmark [http:// www.scanwill.com](http://www.scanwill.com)
Vat-No.: DK-25865316 e-mail: info@scanwill.com
